



# CRANE SCALES



## Digital crane scale

**Model:** ACR i-SZ



### Main technical data

Accuracy Standard	According to OIML class III
Display	58mm (2.3") 5digits LED
Filtering	Low, Medium or High selectable
Units	Kilograms or Pounds selectable
Resolution	2000 to 3000 divisions standard up to 15,000 available
Zero Range	4% F.S.
Tare Range	100% F.S.
Overload Indication	100% F.S. + 9e
Max. Safety Load	125% F.S.
Ultimate Load	400% F.S.
Battery Type	Fully sealed Lead-Acid battery, 6V/7Ah
Battery Life	≥100 hours
Adapter	DC 9V/1000mA
Operating Temperature Range	- 20 C ~ + 50 C
Operating Humidity	≤85% RH under 20 C
Remote Controller Distance	Max. 15m
Battery of Remote Controller	AAA battery, 1.5V x 2
Acceleration of Gravity	9.793, Can be regulated

### Features

- ◆ **Enclosure:**  
Seamless steel pipe extruded for maximum protection.
- ◆ **Multi-weighing units:**  
Kg, lb are selectable, kg are default unit.
- ◆ **Multi-function operation:**  
Tare, Zero, Auto zero tracking, Total, Hold, Overload warning and record, operated through infrared remote controller.
- ◆ **User-friendly design:**  
Large red 5 digit LED display (digit height 58mm), Battery Operated with low battery indication, Automatic turn off , power-saving function.
- ◆ **Gravity regulation:**  
The acceleration of gravity can be regulated through remote controller according to different places value.
- ◆ **Multi options:**  
RS-232-continuous or on demand data output, user-selectable. Wireless big screen 3" , 5" , wireless indicator 180, 280, 380, 580 can match with the scale, user-selectable.

ACR

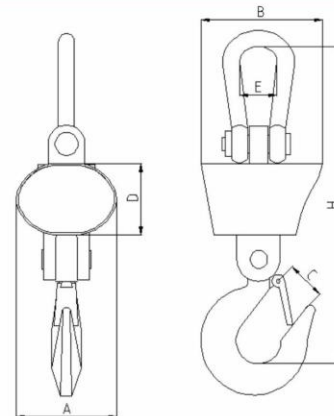

### Dimensions and Specifications

MODEL	Cap.(kg)	Resolution (kg)	A(mm)	B(mm)	C(mm)	D(mm)	E(mm)	H(mm)	N.W.(kg)	G.W.(kg)
ACR iZ-30	30000	10	380	460	110	280	160	1150	165	180
ACR SZ-50	50000	20	490	660	160	340	230	1700	480	510



**ADITSAN TECHNOLOGICAL PRODUCTS**

Office : 102, South Ex Plaza - II, 209 Masjid Moth, New Delhi - 110049.  
Ph. No. : 011-26252010

[www.excellweighing.com](http://www.excellweighing.com)